

# SolaraShade™

Shades that inspire.

INSTALLATION GUIDE

## Curved

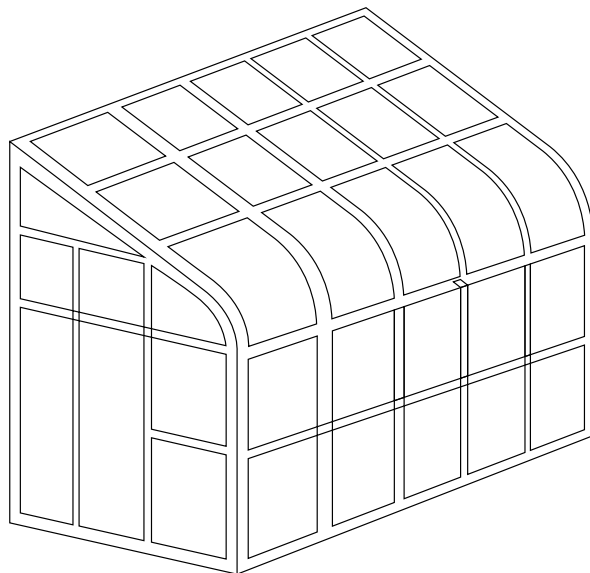

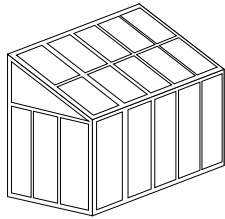

SolaraShade™  
**Straight**

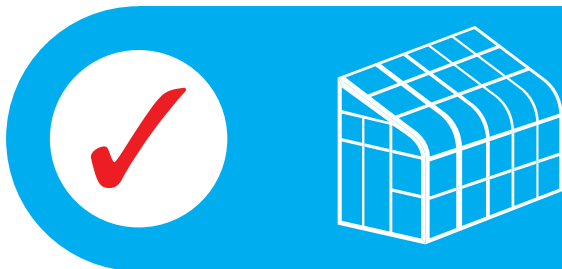

SolaraShade™  
**Curved**

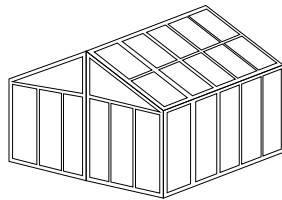

SolaraShade™  
**Cathedral**

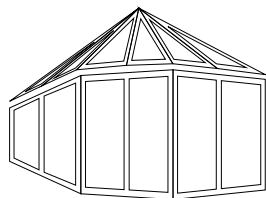

SolaraShade™  
**Conservatory**  
Rectangle & Triangle

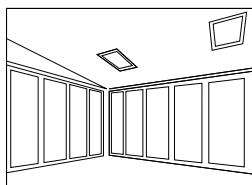

SolaraSky™  
**Skylight**

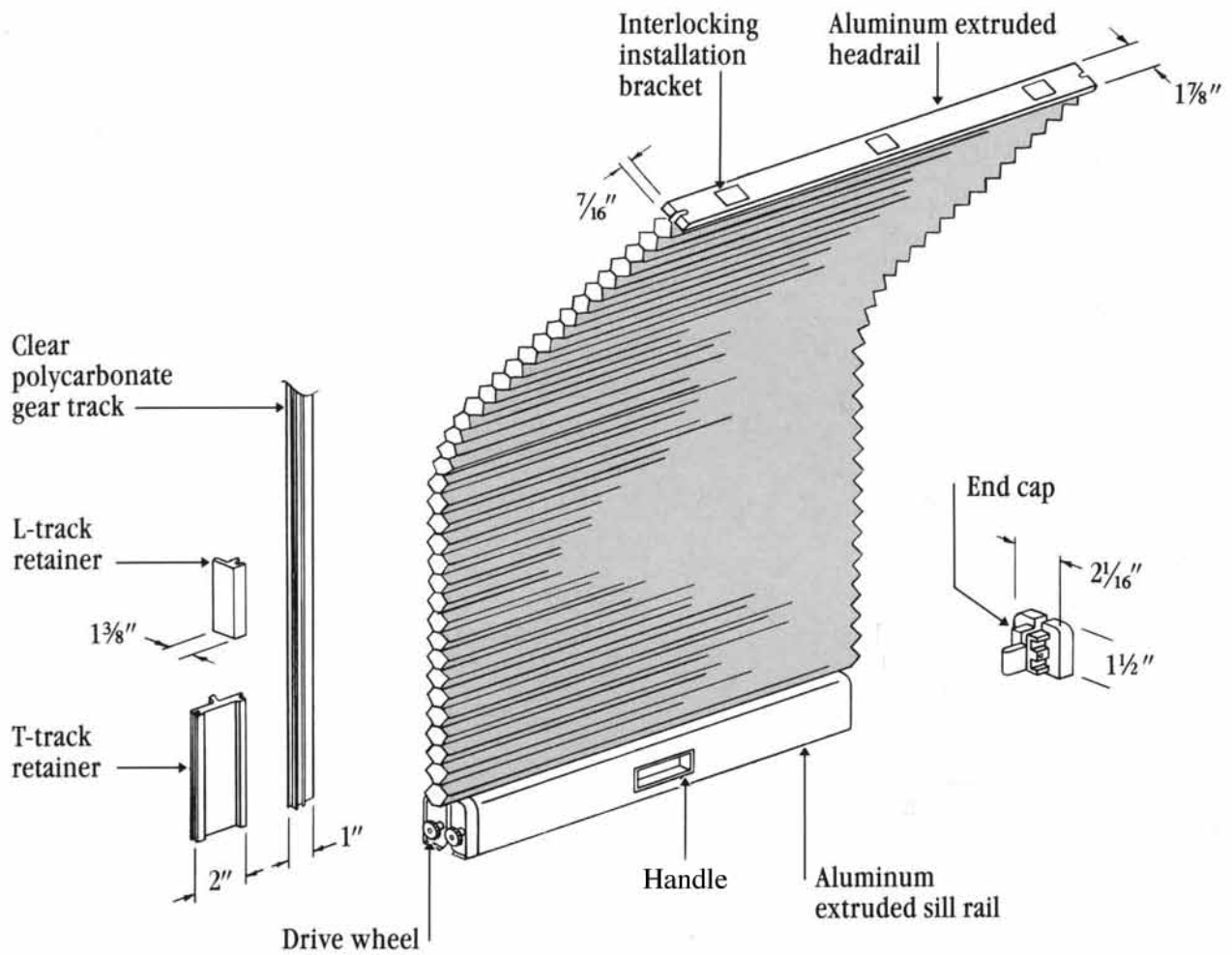

Expanded Hardware Diagram

1.) Start out by uncoiling the gear track.

2.) Starting at one end, carefully apply the first layer of 3/4" tape.

3.) Be sure to start the first layer so that it doesn't cover the ribbed section of track and properly folds over to cover both sides of the track.

4.) Apply the 2nd layer of tape. Continue applying the tape as required. Usually 2 to 3 layers for aluminum glazing bars and 4 to 7 layers for wood glazing bars.

➤ *Sometime the glazing bar pinches in slightly at the curved area so that less tape is required at the rounded section of the beam.*

5.) Snip off the bottom of the gear track to get a clean 90° cut.

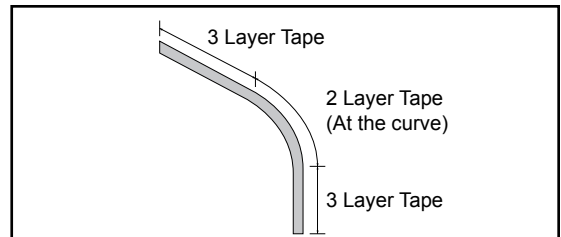
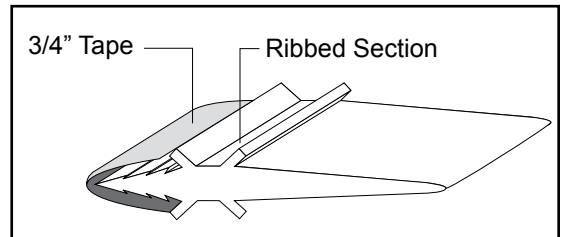

- 6.) While pushing the gear track down against the sill, start tapping it into the channel with the rubber mallet.



- 7.) Continue inserting taped gear track into glazing bar with a rubber mallet.

➤ *Pay close attention that the gear track does not lift off the sill as you continue gently hammering it into the glazing bar.*



- 8.) Once about 24" from the top, eyeball the top of the track and cut the track slightly longer than the ridge.



- 9.) Carefully snip off the top of the gear track to get a clean 90° cut a second time so that it fits tight against the ridge.

➤ *Be very careful not to cut this track short of the ridge.*



- 10.) The proper gap between the top of the gear track to the ridge can be no more than 1/4".

➤ *Make it as close as possible and try not to have any gap.*



- 11.) Hammer in the gear track so that it is completely inserted into the side channel.



- 12.) Continue the same sequence to the other side. Once both gear tracks are fastened, prepare to install the movable rail.



- 13.) Back off both tensioning screws with a flat head screwdriver by about 1/8" to 1/4".



- 14.) Insert the shade into the gear tracks in a diagonal fashion.



- 15.) Carefully inspect fabric to ensure it is centered within the gear tracks.



- 16.) Slowly push/pull the shade to get it level.



- 17.) Gently pry the front and back gear wheels to ensure they ride in the ribbed section of the gear track.

➔ *Ensure that all four gear wheels are properly positioned.*

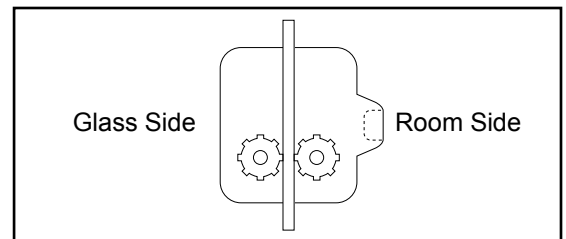
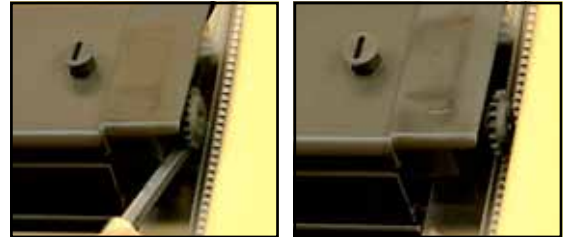

- 18.) Lower shade down to the sill. Gently tighten the tension screws until they just make contact with the base of the movable rail.

➔ *Do not over tighten these plastic screws.*



- 19.) Make sure movable rail handle is unlocked and slide shade up towards the ridge.



- 20.) See how the swivel mount bracket attaches on to the shade headrail.



21.) Mount two swivel brackets into the ridge (middle of bracket is at the same depth as the side track). Brackets are installed about 1" away from the ends of the tracks.



22.) Slide the swivel arm back, push headrail on to brackets and lock swivel arms by pushing back towards the headrail.



23.) Lower shade and ensure that moveable rail is level with sill.



➤ *Double check plastic bolts for proper tension setting. Proper tension means: movable rail should slide easily within the gear tracks without free falling.*



24.) Test the locking feature of the handle. Slide the handle to the left and the shade will lock.



25.) Slide handle to the right to unlock movable rail.

➤ *For bottom stacking applications, slide handle to the left to unlock movable rail.*

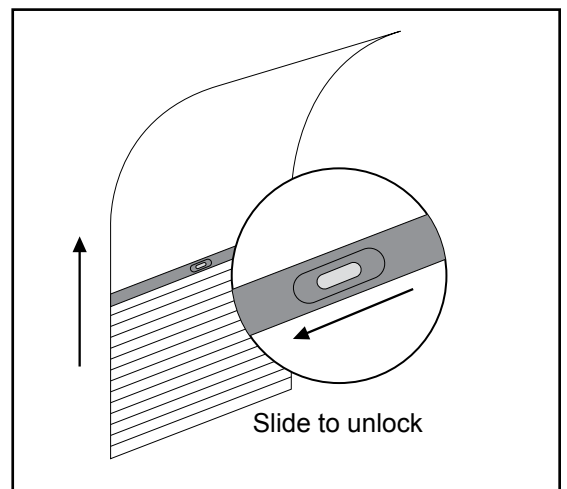

26.) Twist open telescopic wand and insert into plug handle to operate the shade when beyond your reach.

➤ *Be careful not to accidentally lock handle while raising or lowering the shade.*

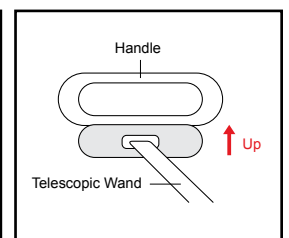
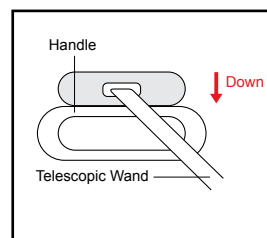
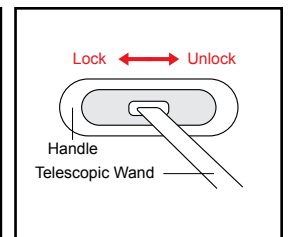
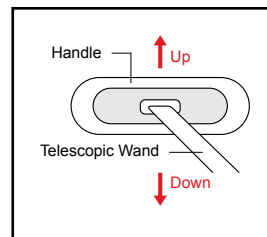

## Trouble Shooting

	Problem	Solution
A	The shade does not raise and lower evenly.	<ul style="list-style-type: none"> <li>Lower the shade to sill, back off on tensioning screw, push down against sill until rail is level retighten tensioning screw.</li> </ul>
B	The shade headrail will not fit into the mounting brackets.	<ul style="list-style-type: none"> <li>Make sure brackets are properly positioned &amp; swivel arms are re-tracked.</li> </ul>
C	Shade is too stiff to easily travel open or closed.	<ul style="list-style-type: none"> <li>Reduce tension on screws.</li> </ul>
D	Shade is too loose and slides too freely with in slide tracks.	<ul style="list-style-type: none"> <li>Tighten tensioning screws.</li> </ul>

## Care and Cleaning

Honeycomb shades are made of an anti-static, dust-resistant fabric which repels dirt and dust. For most honeycomb fabrics, the following options are available if your shade needs cleaning.

### DUSTING

Regular light dusting with a feather duster is all the cleaning that is needed in most circumstances.

### VACUUMING

Use a hand-held vacuum with low suction for more thorough dust removal.

### SPOT-CLEANING

- Prepare a solution of warm water and a mild detergent.
- Dampen a clean cloth in the solution and wring it out.
- Dab the spot with the dampened cloth until it is gone. Do not rub the fabric.
- Allow the shade to dry in the completely lowered position.

### DEEP CLEANING

- Immerse the shade in a basin or bathtub filled with a mild detergent. Never immerse the headrail into the solution.
- Rinse with clean water.
- Fully raise the shade and tilt to eliminate excess water.
- Reinstall the damp shade, lower it, and let it dry completely.

### ULTRASONIC CLEANING

Some honeycomb fabrics can be ultrasonically cleaned by a professional.

- Specify that a mild detergent solution be used.
- Never immerse the headrail into the solution.
- Dry the shade completely in the lowered position.

[www.solarashade.com](http://www.solarashade.com)



3206 Yonge Street, Toronto, Ontario M4N 2L2 Tel: 416-488-6600 1-866-BRADING (272-3464) [www.bradingfabrication.com](http://www.bradingfabrication.com)